

Nikuni Micro-Bubble Generator Technical Handbook



KTM Karyu Turbo Mixer

Introduction

NIKUNI' s unique compact micro-bubble generating KTM pumps, along with a small amount of chemical aid, remove contaminant particles in water purifying plants.

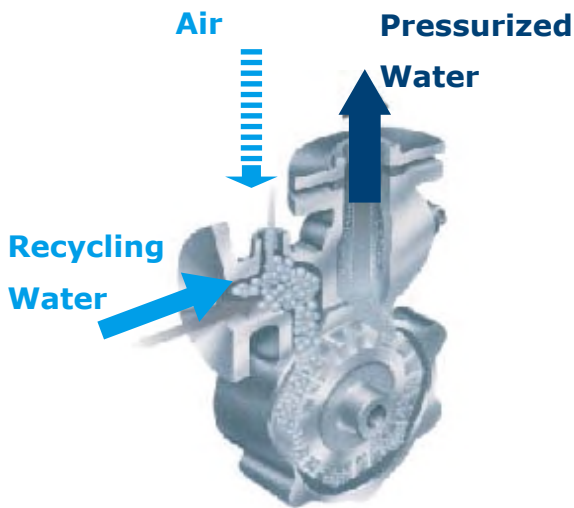

Suction, Mixing / Dissolving and Pressurization with only a single KTM pump

The KTM has a highly precise and sophisticated pumping mechanism that generates plenty of micro-bubbles using three hydro-dynamic principles:

Negative pressure sucks both air and water simultaneously from eachport; air is effectively mixed into water; pressurized air-enriched discharge is produced.

The pressurized air-enriched water is transferred into the bottom of the dissolved air flotation tank. It then makes a layer of micro-bubbles, spreads and floats up to the water surface, and finally forms a sludge mat that will be skimmed off.

KTM Selection Guide

The KTM series, with a wide selection for suitability with various plant designs, are roughly classified into three types; close-coupled type, bare shaft pump and coupling type.

Material of the wetted parts can be selected in cast iron (stainless steel impeller and shaft), SS304, or SS316 for each series. In addition, a check valve with an injection nozzle will be packed in every KTM package.

1. Coupling Type

The coupling type KTM models are most popular in the market. Nikuni will supply a bare pump, pump base (base-plate), and coupling set with coupling guard only.

Depending on your plant site environmental situation, various type of electric motor protection can be applied.

2. Bare Shaft Pump

The core of the coupling type, including only the bare pump. The base and coupling are not included.

3. Close-coupled Type / Monoblock Type

A series of the most compact and complete set of the micro-bubbles generator has been put in our arrangement, eliminating pump base. This option is restricted within the range of KTM20N/F to KTM40N/F.

Features of KTM

Typical schematic drawing of DAF system

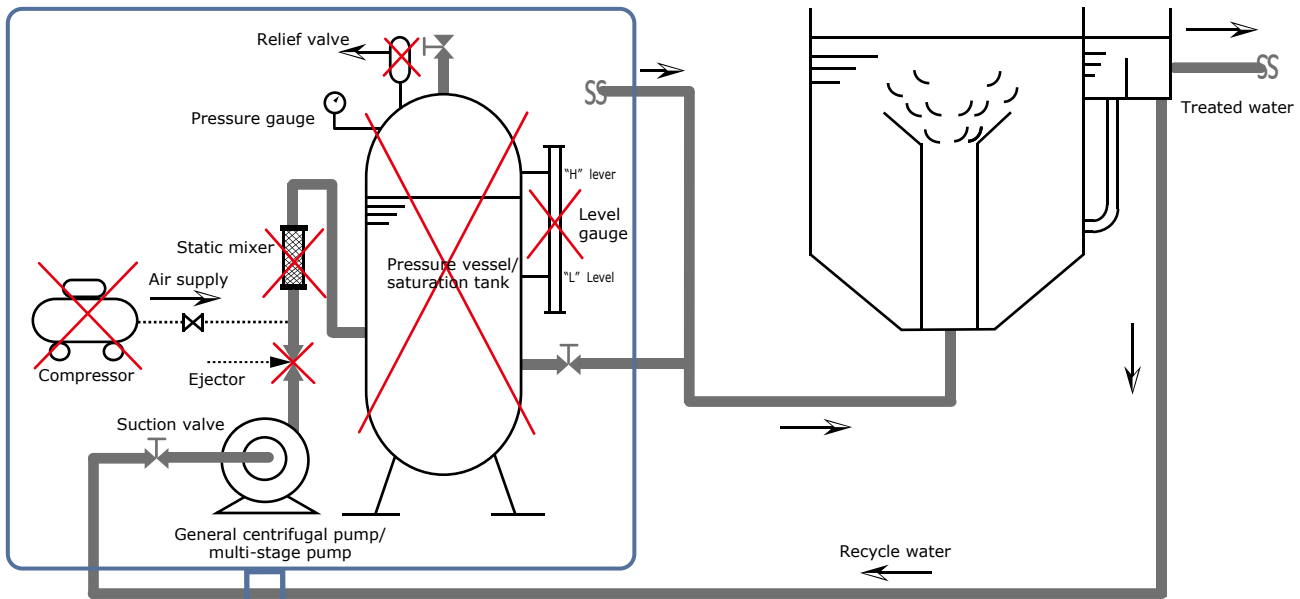

* Note: Ancillary components marked with X are not required for KTM

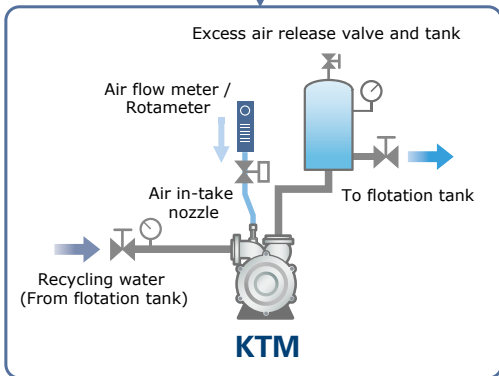

Comparison on basic principal of general centrifugal pump with KTM

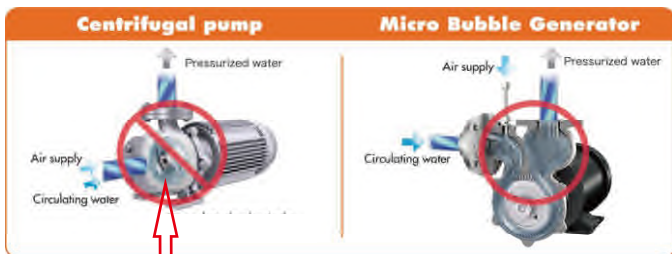

Air pocket develops in the center of casing causing failures of suction

Advantages of KTM compared to Conventional System

1. Three functions in one pump

- The KTM simultaneously draws in air and water, dissolves air with its turbine impeller, and pumps pressurized water to the flotation tank or other process

2. Highly Efficient Air-water Dissolution

- Precision turbine pump technology and a unique design make possible extremely high levels of efficiency in dissolving air into water

3. Simplified DAF Operation and

Stable Pump Performance

- The multifunctional KTM eliminates the need for ancillary equipment such as air compressors, large saturation tanks with difficult level control, and truly simplifies DAF systems and their operation

4. Compact and Small Footprint

- Easily retrofit or upgrade existing DAF systems

5. Minimal Power Consumption and Maintenance Cost

- Highly efficient process with only a small pump and motor, no compressor power required, while the simple and robust structure of the KTM minimizes maintenance cost

KTM selection chart

Performance Table

Close-coupled / Monoblock type

Model	50Hz Frequency				60Hz Frequency			
	Water Flow Rate		Air Flow Rate	Motor Power	Water Flow Rate		Air Flow Rate	Motor Power
	L / min	m ³ / h	NL / min (Range)*	kW / Poles	L / min	m ³ / h	NL / min (Range)*	kW / Poles
KTM20F(N)D-04P(S)	17	1.0	1.3 (0 to 5)	0.56kW/2P	Not available for 60Hz frequency			
KTM20F(N)D-07P	Not available fo 50Hz frequency				22	1.3	1.7 (0 to 5)	0.56kW/2P
KTM25F(N)D-07P	25	1.5	2.0 (0 to 5)	0.975kW/2P	Not available for 60Hz frequency			
KTM25F(N)D-15P	Not available fo 50Hz frequency				67	4.0	5.3 (0 to 10)	1.975kW/2P
KTM32F(N)D-15P	80	4.8	6.4 (0 to 20)	1.975kW/2P	117	7.0	9.3 (0 to 20)	1.975kW/2P
KTM40F(N)D-22P	133	8.0	11.0 (0 to 20)	2.42kW/2P	192	11.5	15.0 (0 to 30)	2.42kW/2P

***Note:**

- Values in brackets show the recommended range of the air flow meter
- Model code
 - F = Wetted parts in cast iron material with stainless steel impeller and shaft
 - N = Wetted parts in standard SS304 material, SS316 as optional models also available

Coupling connection / Base-mounted model

Model	50Hz Frequency				60Hz Frequency			
	Water Flow Rate		Air Flow Rate	Required Motor Power	Water Flow Rate		Air Flow Rate	Required Motor Power
	L / min	m ³ / h	NL / min (Range)*	kW / Poles	L / min	m ³ / h	NL / min (Range)*	kW / Poles
KTM20F / N	17	1.0	1.3 (0 to 5)	0.75kW/2P	22	1.3	1.7 (0 to 5)	0.75kW/2P
KTM25F / N	25	1.5	2.0 (0 to 5)	1.5kW/2P	42	2.5	3.3 (0 to 5)	1.5kW/2P
KTM32F / N	50	3.0	4.0 (0 to 10)	2.2kW/2P	67	4.0	5.3 (0 to 10)	2.2kW/2P
KTM40F / N	80	4.8	6.4 (0 to 20)	3.7kW/2P	117	7.0	9.3 (0 to 20)	3.7kW/2P
KTM50F1 / S1	133	8.0	11.0 (0 to 20)	5.5kW/4P	192	11.5	15.0 (0 to 30)	7.5kW/4P
KTM50F2 / S2	200	12.0	16.0 (0 to 20)	7.5kW/4P	250	15.0	20.0 (0 to 40)	11kW/ 4P
KTM50F3 / S3	250	15.0	20.0 (0 to 30)	11kW/ 4P	300	18.0	24.0 (0 to 40)	15kW/ 4P
KTM65F2 / S2	333	20.0	27.0 (0 to 40)	15kW/ 4P	467	28.0	37.0 (0 to 60)	18.5kW/4P
KTM80F / S	700	42.0	56.0 (0 to 80)	22kW/ 4P	967	58.0	77.0 (0 to 100)	30kW/ 4P

***Note:**

- Values in brackets show the recommended range of the air flow meter
- Model code
 - F = Wetted parts in cast iron material with stainless steel impeller and shaft
 - N & S = Wetted parts in standard SS304 material, SS316 as optional material is also available

Configurations

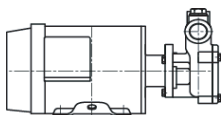

Close-coupled / Monoblock type

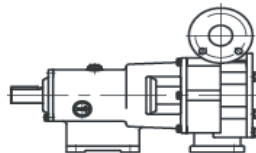

Bare shaft pump only
(Refer to page 7 for standard base-plate dimensions)

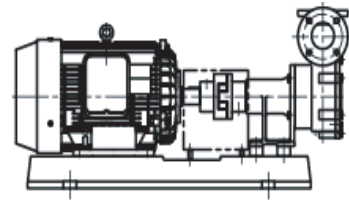

Coupling connection / Base-mounted model
(Electric motor will not be supplied by NIKUNI)

Dimensions

Technical Description of Air-Intake Nozzle

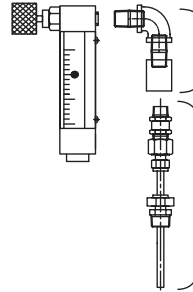
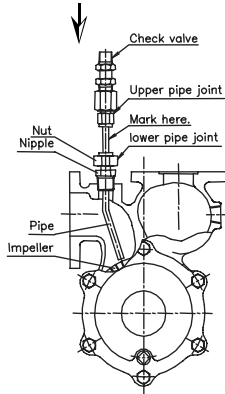

- Note:
1. Fitting connections and air flow meter / rotameter should be prepared by purchaser
 2. Air in-take nozzle will be attached for every KTM

Configuration of Air-Intake Nozzle mounted in KTM

Dimensions

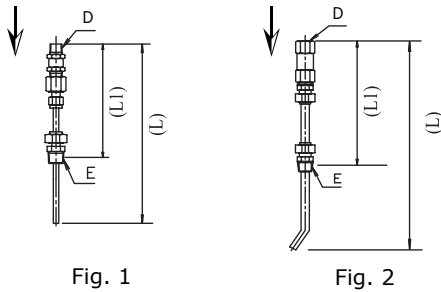

Unit : mm

Applicable model	Figure	Dia.(E)	Dia.(D)	Length(L1)	Length(L)
KTM20F/FD (N/ND)	Fig.1	R 1/4 (R 3/8)	R 1/4	121	209
KTM25F/FD (N/ND)		R 1/4 (R 3/8)	R 1/4	121	218
KTM32F/FD (N/ND)		R 1/4 (R 3/8)	R 1/4	121	235
KTM40F/FD (N/ND)		R 1/4 (R 3/8)	R 1/4	121	241
KTM50F1/F2/F3/S1/S2/S3	Fig.2	R 3/8	R 1/4	129	339
KTM65F2/S2		R 3/8	R 3/8	183	304
KTM80F/S		R 3/8	R 3/8	193	319

Close-coupled / Monoblock Type

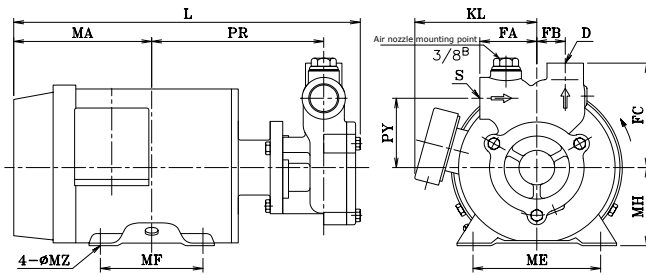

Unit : mm,kg

Model	S	D	PR	PY	FA	FB	FC	MH	L	MA	ME	MF	MZ	KL	Weight
KTM20ND04S	Rc 3/4	Rc 1/2	165	63	50	25	95	80	312	115	125	100	10x17	91	14
KTM20ND04Z	Rc 3/4	Rc 1/2	151	63	50	25	95	71	304	121	112	90	7x8	107	12
KTM20ND07Z	Rc 3/4	Rc 1/2	145	63	50	25	95	80	325	148	125	100	10x8	146	18
KTM25ND07Z	Rc 1	Rc 3/4	145	70	60	28	105	80	331	148	125	100	10x8	146	22
KTM25ND15Z	Rc 1	Rc 3/4	168	70	60	28	105	90	361	155	140	125	10x12	156	26
KTM32ND15Z	Rc 1 1/4	Rc 1	168	80	65	35	120	90	366	155	140	125	10x12	156	27
KTM40ND22Z	Rc 1 1/2	Rc 1 1/4	172	85	70	40	130	90	405	184	140	125	10x12	156	32

Dimensions

Bare Shaft Pump KTM50S1,S2 & S3

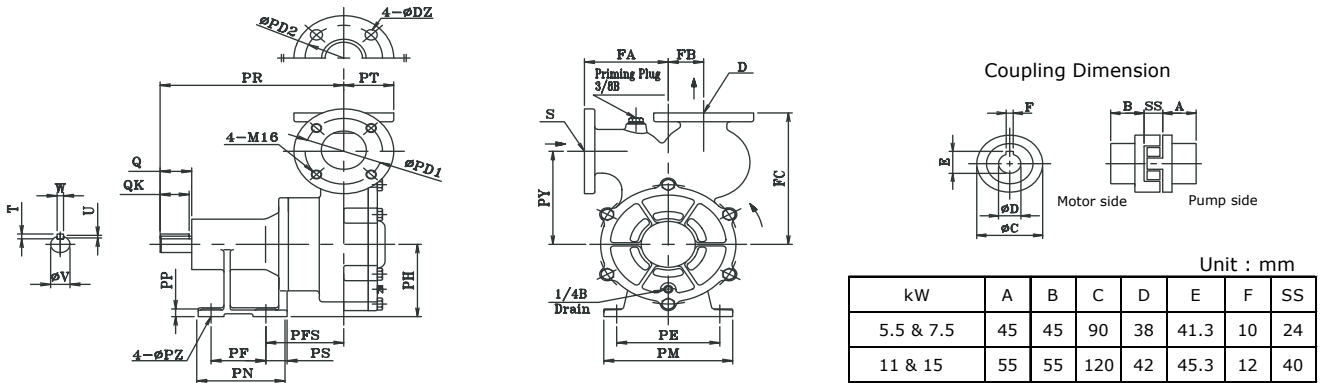

Model	S	D	PR	PY	FA	FB	FC	PE	PM	PT	PD1	PD2	PH	PFS	PS	PF	PN	PP	PZ	Q	QK	T	U	V	W	Weight
KTM50S1	50A	50A	285	160	130	55	230	160	200	77.5	120	120	132	121	33	85	138	14	14	49	45	7	3	30	8	45
KTM50S2	50A	50A	285	170	130	55	240	160	200	77.5	120	120	132	121	33	85	138	14	14	49	45	7	3	30	8	50
KTM50S3	50A	50A	285	170	130	55	240	160	200	77.5	120	120	132	121	33	85	138	14	14	49	45	7	3	30	8	50

Bare Shaft Pump KTM65S2 & 80S

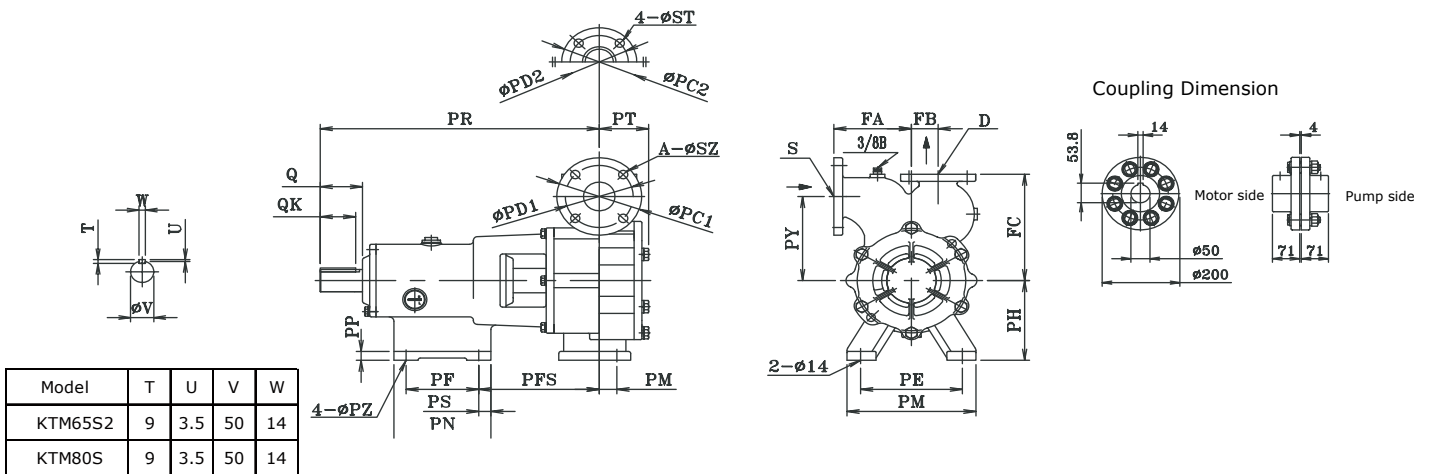

Model	S	D	PR	PY	FA	FB	FC	PH	PE	PM	PT	PD1	PD2	PC1	PC2	PM	PFS	PS	PF	PN	PP	PZ	SZ	ST	TZ	Q	QK	Weight	
KTM65S2	65A	50A	575.5	190	160	55	240	180	210	266	102	140	120	175	155	36.5	248.5	25	150	200	20	14	19	19	230	280	87	74	150
KTM80S	80A	65A	582	180	170	80	280	180	270	326	127	150	140	185	175	45	255	25	150	200	20	19	19	19	230	280	87	74	200

Dimensions

Coupling Connection / Base-mounted Type

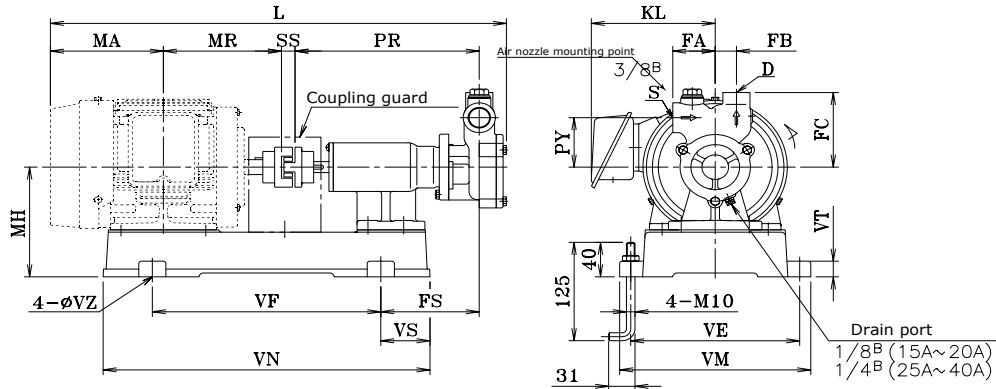

Unit : mm,kg

Model	S	D	PR	PY	FA	FB	FS	FC	MH	L	MA	MR	SS	VE	VF	VM	VN	VS	VT	VZ	KL	Weight
KTM20N	Rc 3/4	Rc 1/2	218	63	50	25	116	95	140	526	122	140	14	199	269	225	385	58	20	12	146	27
KTM25N	Rc 1	Rc 3/4	224	70	60	28	129	105	150	604	155	169	18	214	300	240	430	65	20	12	156	36
KTM32N	Rc 1 1/4	Rc 1	224	80	65	35	129	120	150	609	155	169	18	214	300	240	430	65	20	12	156	42
KTM40N	Rc 1 1/2	Rc 1 1/4	238	85	70	40	82	130	180	692	186	200	18	280	425	310	616	96	25	12	175	61
KTM20F	Rc 3/4	Rc 1/2	214	63	50	25	112	95	140	522	122	140	14	199	269	225	385	58	20	12	146	27
KTM25F	Rc 1	Rc 3/4	219	70	60	28	124	105	150	599	155	169	18	214	300	240	430	65	20	12	156	36
KTM32F	Rc 1 1/4	Rc 1	224	80	65	35	129	120	150	609	155	169	18	214	300	240	430	65	20	12	156	42
KTM40F	Rc 1 1/2	Rc 1 1/4	238	85	70	40	82	130	180	692	186	200	18	280	425	310	616	96	25	12	175	61

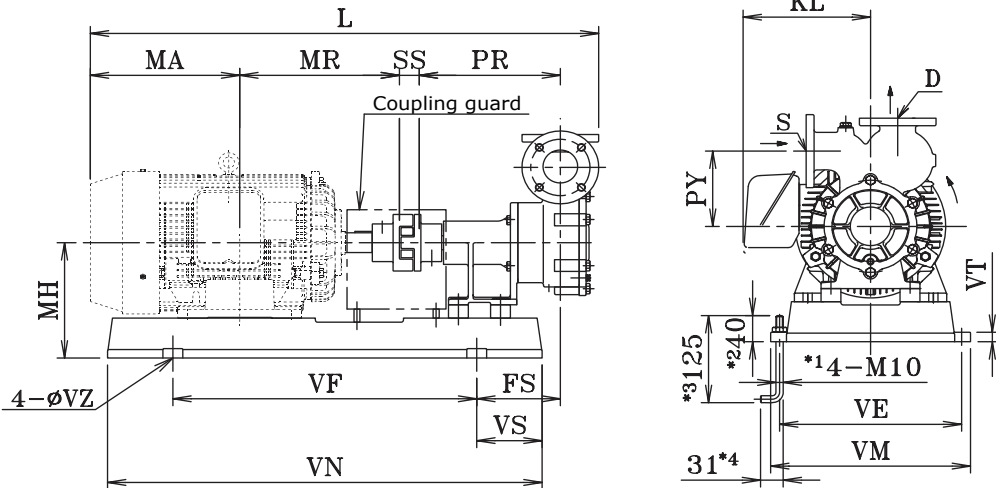

Unit : mm,kg

Model	kW	S	D	PR	PY	FA	FB	FS	FC	MH	L	MA	MR	SS	VE	VF	VM	VN	VS	VT	VZ	KL	Weight
KTM50F1/S1	5.5	50A	50A	285	160	130	55	150	230	204	836	211	239	24	324	448	352	690	121	20	12	189	105
	7.5	50A	50A	285	160	130	55	160	230	204	874	230	258	24	324	448	352	690	121	20	12	189	111
KTM50F2/S2 KTM50F3/S3	7.5	50A	50A	285	170	130	55	160	240	204	874	230	258	24	324	448	352	690	121	20	12	189	115
	11	50A	50A	285	170	130	55	169	240	245	1028	302	323	40	368	614	404	878	132	20	15	256	162
KTM65F2/S2	15	65A	50A	576	190	160	55	103	240	300	1277	250	345	4	462	835	512	1285	225	30	19	256	303
	18.5	65A	50A	576	190	160	55	103	240	300	1353	292	352	4	462	835	512	1285	225	30	19	335	338
KTM80F/S	22	80A	65A	582	180	170	80	109	280	300	1356	292	352	4	462	835	512	1285	225	30	19	279	372
	30	80A	65A	582	180	170	80	40	280	360	1429	346	371	4	356	950	430	1250	150	18	19	314	498

Recommendation of Baseplates Dimensions

KTM_N/F Series

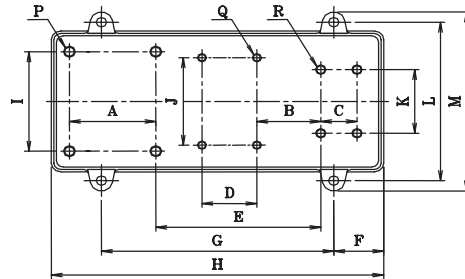
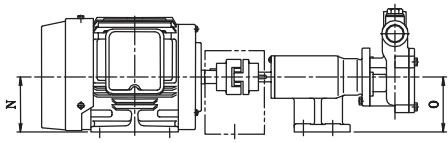

Fig.1

KTM50S/F Series

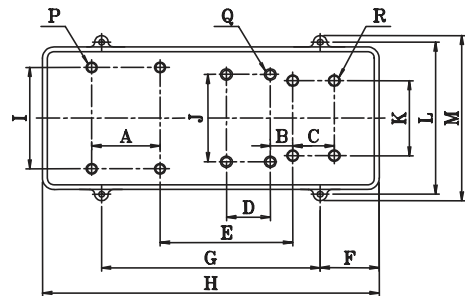
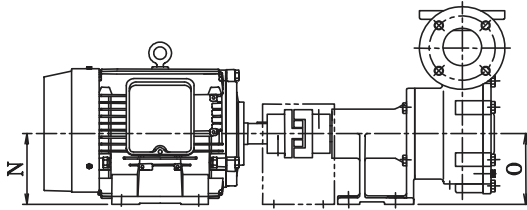

Fig.2

KTM65 & 80S/F Series

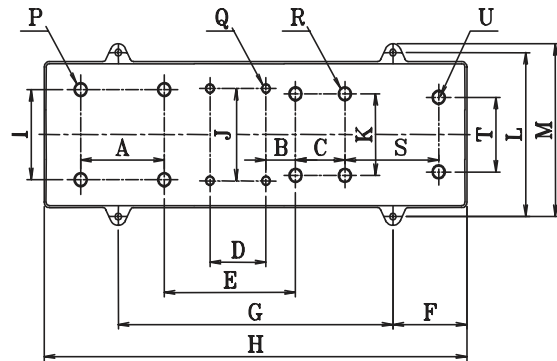
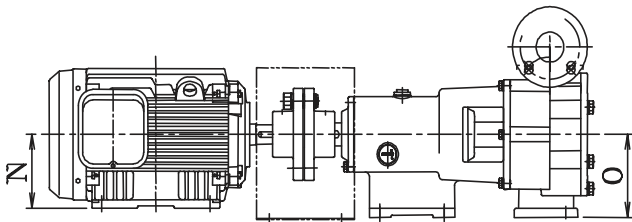

Fig.3

Unit : mm

Model	Figure	kW	A	B	C	D	E	F	G	H	I	J	K	L	M	N	O	P	Q	R	S	T	U	
KTM20N	Fig. 1	0.75	100	97	42	-	191	58	269	385	125	90	80	199	225	80	80	4-M8	2-M6	4-M10	-	-	-	
KTM25N		1.5	125	90	42	-	211	65	300	430	140	120	80	214	240	90	80	4-M8	2-M8	4-M10	-	-	-	
KTM32N		2.2																						
KTM40N		3.7	140	70	58	90	254	96	425	616	190	130	100	280	310	112	90	4-M10	4-M8	4-M10	-	-	-	
KTM50S1	Fig.2	5.5	140	48	85	90	272	121	448	690	216	178	160	324	352	132	132	4-M10	4-M8	4-M12	-	-	-	
		7.5	178	48	85	90	272	121	448	690	216	178	160	324	352	132	132	4-M10	4-M8	4-M12	-	-	-	
KTM50S2 KTM50S3		7.5	178	48	85	90	272	121	448	690	216	178	160	324	352	132	132	4-M10	4-M8	4-M12	-	-	-	
	11	210	45	85	160	337	132	614	878	254	190	160	368	404	160	132	4-M12	4-M8	4-M12	-	-	-		
	15	254	45	85	160	337	132	614	878	254	190	160	368	404	160	132	4-M12	4-M8	4-M12	-	-	-		
KTM65S2	Fig.3	15	254	90	150	170	399	225	835	1285	254	260	230	462	512	160	180	4-M12	4-M8	4-M12	285	210	2-M12	
		18.5	241	90	150	170	412	225	835	1285	279	260	230	462	512	180	180	4-M12	4-M8	4-M12	285	210	2-M12	
KTM80S		22	241	90	150	170	412	225	835	1285	279	260	230	462	512	180	180	4-M12	4-M8	4-M12	300	270	2-M12	
	30	279	95	150	170	412	150	950	1250	279	260	230	356	430	180	180	4-M12	4-M8	4-M12	300	270	2-M12		

Technical Description of KTM Installation

Generic Flow Diagram

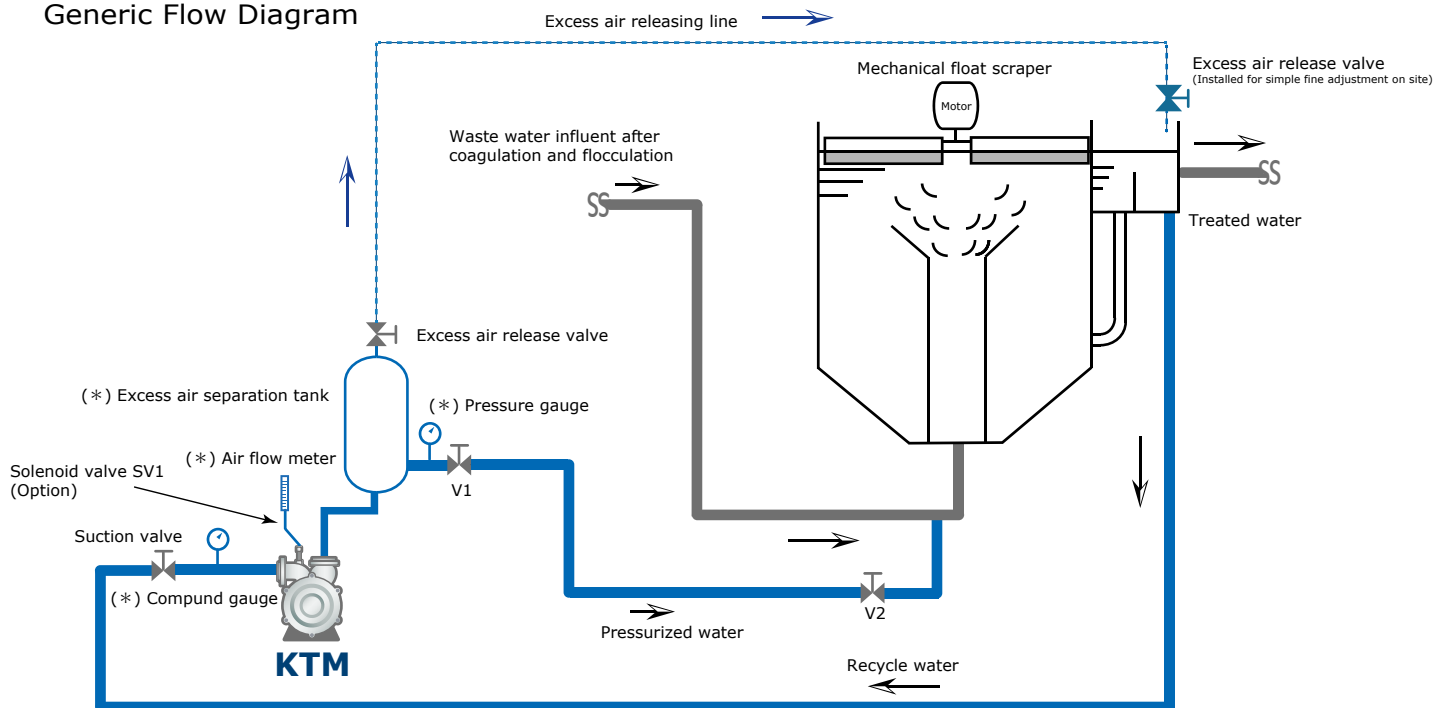

(*) Please refer to the catalog for more details

Initial Adjustments

1. All of the necessary valves, gauges, and the air parameter should be installed properly before operation.
2. Prime water into the KTM.
2. Inching test - Check whether the KTM is rotating smoothly in the prescribed direction.
3. Suction and discharge valves should be fully opened and the air parameter or rotameter should be fully closed before turning on the power.
4. After checking that the KTM is operating correctly, close the discharge valve as to lift the discharge pressure up to 0.4MPa (4 Bar / 58psi).
5. Close the suction valve as to set the suction pressure to a negative pressure range within -0.02 to -0.03MPa (-0.2 to -0.3 Bar / -3 to -4.5psi).
6. Open the air valve of the air flow meter or rotameter as to drawn in the prescribed air flow into the KTM. Refer to page 3 for the recommended air capacity for each model.
7. Slightly open the "excess air release valve" as to release surplus air with a small amount of water from the top of the separation tank back to the source of the treated water tank. Optimal water flow rate is approximately 0.5 L/min.
8. If the KTM and separation tank are installed far from the flotation tank, install a valve (V2) close to the dosing point at the flotation tank. In this case adjust the discharge pressure at this point and fully open V1 during operation.
9. For the system where the KTM has negative suction head, install a solenoid valve (SV1) at the air drawn-in line between flow meter or rotameter and the KTM. Set the air valve to open with approximately a 60 second delay after starting the operation of KTM as to let water fully prime the KTM before air injection. Set that valve to close when operation is stopped.
10. To simplify adjustments of the surplus air capacity, another "excess air release valve" is recommended to be installed close to the source of the treated water tank.